

# PRORIL

60 Hz

Designed for light weight, excellent performance, low energy consumption, and easy maintenance, PRORIL submersible handy pumps serve a wide range of pumping applications on utility, construction, industrial, and municipal job sites.

Handy and Residue Pump

## SAVVY JUMBO 600

Handy Pump



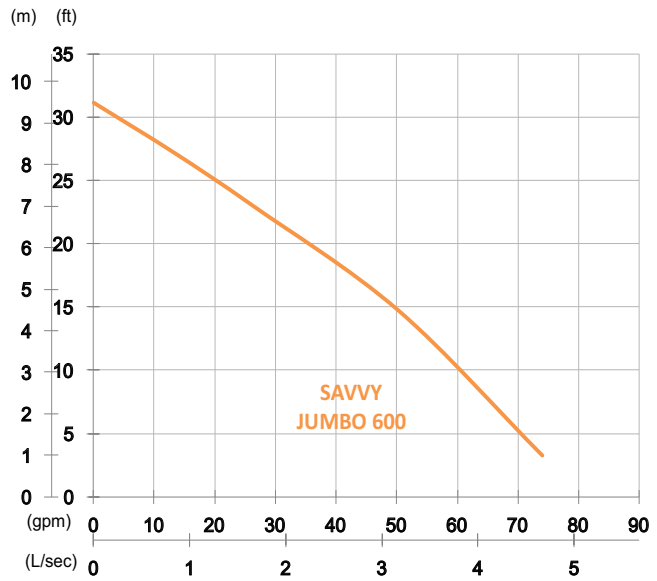

Shaft Speed : 3450 rpm

Outlet : 50mm, 2in

OUTPUT	HEAD	FLOW
0.55 kW	Rated : 7m, 23ft	Rated : 1.7 L/s, 26 gpm
0.75 HP	Max : 9.5m, 31ft	Max : 4.7 L/s, 74 gpm

Solid Passage : 35mm, 1.4in

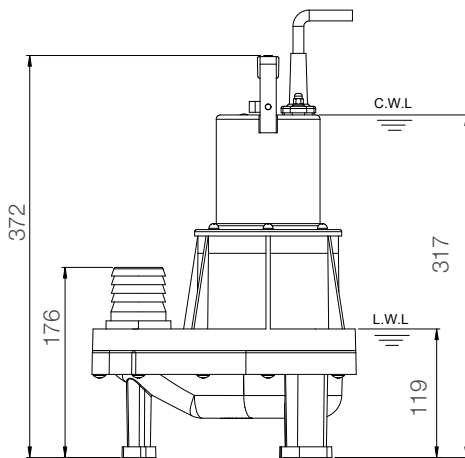
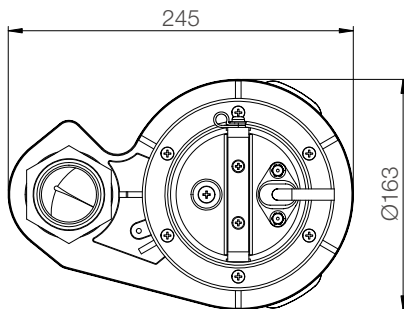

unit : mm

Weight : 6kg / 13 lbs

Pump Type	Electric Submersible Pumps	
	1-Phase	
Motor	Type	Induction Motor
	Poles	2 Pole
	Insulation	Class F
	Protector	Miniature Thermal Protector
	Starter	Capacitor-Run
Lubricant	Food Grade (ISO VG115)	
Impeller Type	Vortex	
Shaft Seal	Single Mechanical Seal	
	Ceramic / Carbon	
Bearings	C3 Shielded ball bearings	
Cable	PVC (CSA Certified) / H07RN-F	
	6m (20ft) or longer upon request.	
Materials	Pump Casing	Synthetic Polymers
	Impeller	Synthetic Polymers
	Motor Frame	Stainless Steel
	Motor Shaft	Stainless Steel
Max. Liquid Temperature	40°C (104°F)	
Max. Submersion Depth	10m (33ft)	
pH Range	pH 5 - pH 8	